



MOJZA

9702

AS Levels

PHYSICS

PRACTICAL PAPER 3 GUIDE



UPDATED TO THE
2025-27 SYLLABUS

1st
Edition

MOJZA

AS Level

Physics

P3 NOTES

9702



BY TEAM MOJZA

CONTENTS

Question 1: Full Practical Investigation

Identifying Variables & Errors -----Pg 04

Data Collection (Tables) & Recording -----Pg05

Graph Plotting -----Pg 06

Graph Analysis -----Pg 06

Question 2: Short Practical Tasks

Measurement Techniques -----Pg 07

Recording Data & Precision -----Pg 10

Uncertainty Calculation -----Pg 10

Limitations & Improvements -----Pg 11

Appendices:

Decimal Places -----Pg 12

Instruments & Uncertainty Reference -----Pg 13



Q1: Full Practical Investigation

Identifying Variables & Errors

- Types of Variables:

→ **Independent Variable** the quantity you deliberately change or control in an experiment to observe its effect on the dependent variable.

It goes on the x-axis and is set by you, typically listed in the first column of the table.

→ **Dependent Variable** the quantity that you measure in response to changes in the independent variable.

It goes on the y-axis of the graph and is expected to change because of what you varied.

Typically listed in the second column of the table.

→ **Control Variable** the quantity that must be kept constant throughout an experiment to ensure a fair test and reliable results.

If control variables are not kept constant, they could affect the dependent variable and **invalidate** your results.

- Types of Errors:

→ **Systematic Error**

Constant error present in all readings, all the values are either greater or smaller than the true value.

Cannot be reduced by taking average, usually occurs due to issue in measuring devices

Example: zero error

→ **Random Error**

Random fluctuations in readings about the true value.

Reduced by taking average, usually caused by environmental factors (wind) or parallax error.

- Accuracy

How close the set of measured values is to the true value.

- Precision

Measure of how close readings are to each other.

Drawing Tables & Recording Data

- Table Presentation

→ **Layout heading** written on the top row. Units are **only** written in the heading once. Use a pencil and ruler to neatly draw the table, write the values with a pen or pencil.

→ **Reading** take six sets of readings of required values
range= maximum value-minimum value (take readings from in between)

→ **Consistent Significant figures & Decimal Places** all values in a column must have the same number of decimal places, based on the instrument precision. Use minimum significant figures of raw data or one more for your measured data.

→ **Heading** use symbols along with units written in brackets for your raw and calculated data. Note down the number of oscillations you used to measure time before making your table, in the same space.

- Scoring full marks in Table:

six complete readings	5 marks
five complete readings	4 marks
range (highest and lowest value)	1 mark
column headings with correct units	1 mark
consistency to the nearest mm, cm, m	1 mark
significant figures	1 mark
correct calculation	1 mark

- Example Table: (The difference in t should be 0.4-0.5 seconds only)

Sr no.	r(cm)	t ₁ (s)	t ₂ (s)	<T> (s)	T (s)	r ² (cm ²)	T ³ (s ³)
1	15.0	20.91	20.84	20.88	2.09	225.0	9.129
2	20.0	22.44	22.23	22.34	2.23	400.0	11.09
3	25.0	24.18	24.19	24.19	2.42	625.0	14.17
4	30.0	26.28	26.18	26.23	2.62	900.0	17.98
5	35.0	27.75	27.87	27.81	2.78	1225.0	21.48
6	40.0	29.15	29.13	29.14	2.91	1600.0	24.64

Graph Plotting

- How to Plot a Graph (4 marks)

→ **Axes** use a sensible scale that covers more than 50% of the graph.

Mark both origins and continuity arrows.

Add Symbols and their units of values on x and y axes.

→ **Plotting** all six readings must be plotted neatly using a sharpened pencil on the grid to an accuracy of half a small scale.

No blobs, use a cross (x) or draw a small dot and a circle around it neatly.

→ **Scattering of Points** there should be no scatter of points, a type of pattern must be formed when drawing the line of best fit.

→ **Line of Best Fit** even distribution of points on both sides of the line, do not force the line through a point. Draw a smooth curved line if the plotted points give the shape of a curve. No dark lines, use a pencil.

→ **Gradient** choose two points on your line of best fit that are far away and mark them (the further they are lower the percentage error). Draw a triangle using dashed lines.

$$\text{Gradient} = \frac{y_2 - y_1}{x_2 - x_1}$$

Use correct units, without stating the units marks are not received. Show complete working with formula included.

→ **Y-intercept** use equation of straight line to calculate.

$$y = mx + c$$

(m=gradient) (c=y-intercept)

Use any one point on the graph (your line of best fit) and input its x and y coordinates along with the gradient calculated.

The unit for y-intercept is the same unit as the y-axis of the graph. Show complete working with formula included.

Graph Analysis

New equation values are equal to the $y = mx + c$ graph equation, find the required ones by putting these equal to each other.

Always include units—marks are not awarded otherwise.

$$\frac{1}{T} = aV_s + b \text{ and } y = mx + c$$

$\frac{1}{T} = y$	$a = m$	$v_s = x$	$b = c$
-------------------	---------	-----------	---------

Q2: Short Practical Tasks

Measurement Techniques

- Micrometer

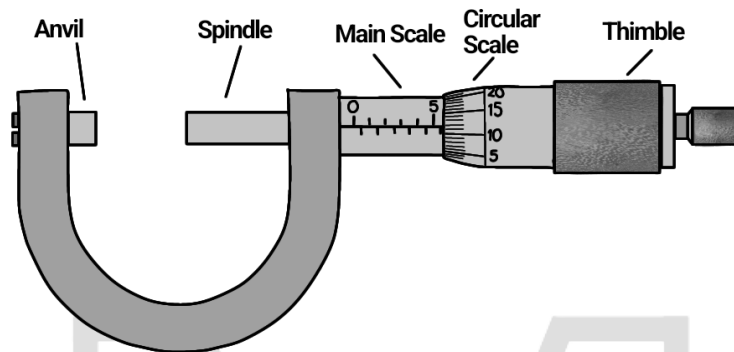

Commonly used to measure diameter of spherical objects.

- place the object between anvil and spindle.
- rotate the thimble, until its held firmly in place.

- Measurement Technique:

- micrometer has a least count of 0.01 mm
- add the values on main scale and rotating scale to get final reading
- **main scale** reading before the turning scale, 2.5 mm according to this diagram
- **turning scale** the reading aligned to the vertical main scale line (datum line), 38 mm into this case. However the turning scale reading **always** has to be multiplied by 0.01 thus 0.38 mm.
- **final reading** $2.5 + 0.38 = 2.88$ mm

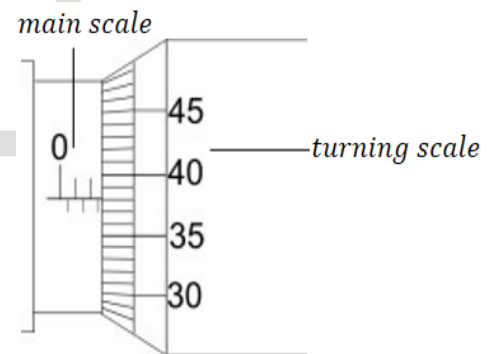

- Zero Error:

- always check for zero error before starting the experiment.
- error can be negative or positive according to position of 0 on thimble scale.
- negative — 0 above datum line
- positive — 0 below datum line
- subtract the zero error from the final reading if present.

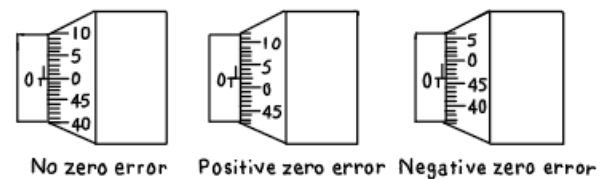

- Vernier Calipers

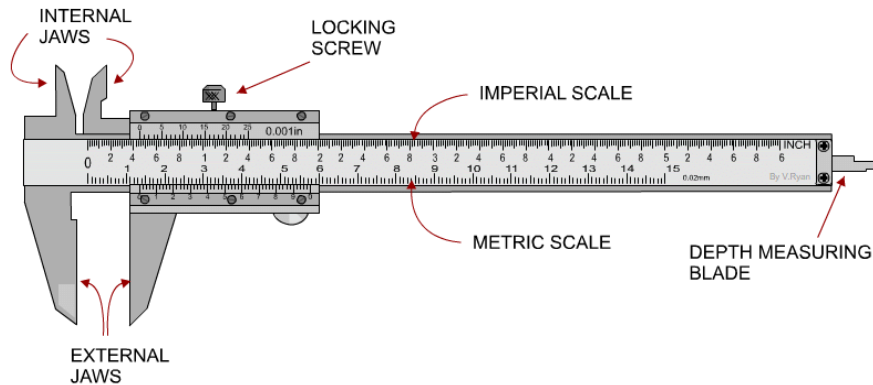

Commonly used to measure diameters of spherical objects or inner and outer diameters of tubes.

- external jaws are used to measure outer diameter.
- internal jaws are used to measure inner diameter.
- place the object between the jaws, push the scale to hold it in place.
- turn the screw to lock it.

- Measurement Technique:

- vernier calipers have a least count of 0.1 mm.
- **main scale** — reading left to the zero of vernier caliper scale. $0.9 \text{ cm} = 90 \text{ mm}$
- **vernier scale** — the reading when both vernier and main scale lines are aligned. 6 cm , the vernier scale reading is always multiplied with least count. $6 \text{ cm} \times 0.01 = 0.06 \text{ cm}$
- **final reading** — main+vernier scale reading $0.9 + 0.06 = 0.96 \text{ cm}$

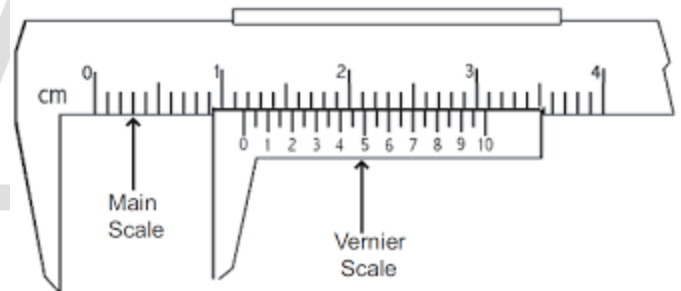

- Zero Error:

- always check for zero error before starting the experiment.
- error can be negative or positive according to position of 0 on vernier scale.
- Negative — 0 on the vernier scale is left of main scale 0.
- Positive — 0 on the vernier scale is right of main scale 0.
- zero error = reading when both main scale and vernier scale lines are aligned $\times 0.01$.

→ in the upper diagram — zero error = 7×0.01

- Multimeter

→ **Voltmeter:** when checking the voltage of a circuit set the dial at 20 V

→ **Ammeter:** when checking the current set the dial at 200mA or 10 A

The reading will always fluctuate and not remain the same, take the average of the multiple readings for increased accuracy.



Recording Data & Precision

Q2 requires students to follow a given set of rules in an experiment that is flawed allowing limitations and improvements to be calculated. Two sets of readings are recorded.

- Measuring different objects length, diameters or angles is common in this question. You need to have a good grasp on how to use the different instruments eg: vernier calipers.
- Units are already mentioned thus make sure to convert your answers in the given units if needed.
- Ensure consistent decimal places in all answers.

- Justifying Significant Figures

The number of significant figures of calculated value of X should be the same as S.F of the measured value of X.

Uncertainty Calculation

- How to calculate Uncertainties

→Absolute Uncertainty

$$\Delta x$$

→Fractional Uncertainty

$$\frac{\Delta x}{x}$$

→Percentage Uncertainty

$$\frac{\Delta x}{x} \times 100\%$$

- Suggested Relationship:

The question will give a limit of experimental accuracy, the percentage uncertainty should be within that limit for suggested relationship to be valid.

$$\frac{k(\text{large}) - k(\text{small})}{k(\text{large})} \times 100\%$$

Limitations & Improvements

Limitations	Improvements
Two-three readings are not enough to make a valid conclusion.	Take more readings and plot a graph.
The value of (physical quantity) is small leading to large percentage uncertainty.	Increase the value (eg increase the distance).
Movement of oscillation affected by wind.	Use a wind shield.
Difficult to determine start and end of a reaction as the object moves too fast.	Use a video camera with slo-mo and timer.
Difficult to release an object without applying force.	Use a mechanical hand to release it.
Heat loss through sides/bottom of the container.	Use a polystyrene cup/container to insulate the beaker.
The instrument is not precise enough.	Use another instrument with greater sensitivity/precision.
Length/Diameter/Thickness of an object is not uniform.	Measure the length around the object and calculate the mean.
Friction at Pulley.	Apply oil to lubricate it.
Hard to see readings through the water surface.	Place a paper behind the beaker.
Inconsistent Bounce/Rebound.	Use a flat surface/no fans.
String/Spring slides off the rod.	Use adhesive putty to position the string/spring to the rod.
The tube gets distorted when measuring internal diameter.	Use a travelling microscope to measure internal diameter.
Volume measured is not accurate as the syringe is not precise.	Use a measuring cylinder instead to measure volume.
Difficult to judge water level due to meniscus problem.	Dye/colour the water.
Resistance of Contacts.	Clean the contacts.

Appendices:

Decimal Places

- Length

- mm — no d.p
- cm — 1 d.p
- m — 3 d.p

- Stopwatch

- s — 2 d.p

- Protractor

- angle — no d.p

- Vernier Caliper

- mm — 2 d.p
- cm — 3 d.p

- Micrometer Screw Gauge

- mm — 2 d.p



Instruments & Uncertainty References

Instruments/Unit of Measurement	Uncertainties
Length	0.1 cm
Stopwatch (digital)	0.01 s
Stopwatch (analogue)	(max-min) \div 2
Protactor	1-2
Syringe	1-2 cm^3
Voltmeter (20V)	0.01 V
Voltmeter (2000V)	1 V
Ammeter (20mA)	0.01 mA
Ammeter (200mA)	0.1 mA

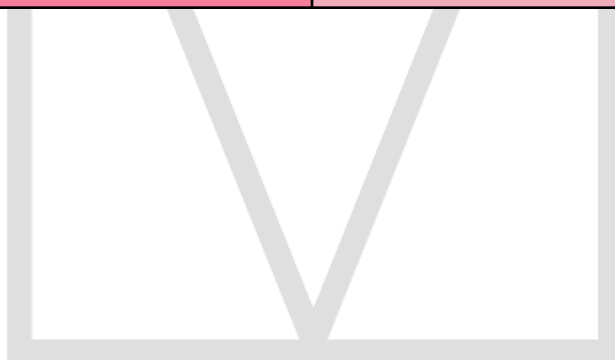

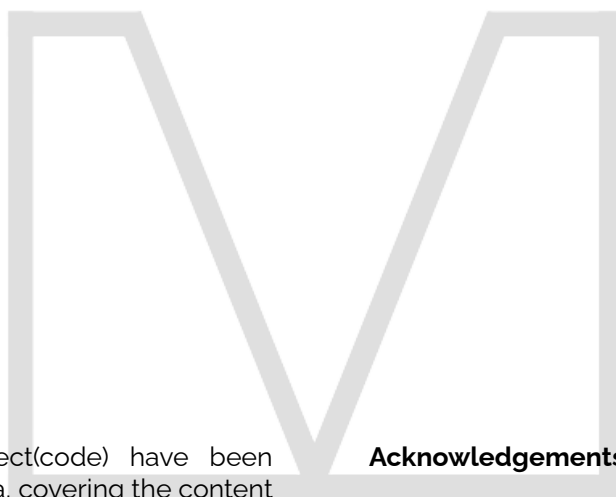

A Note from Mojza

These notes for Subject(code) have been prepared by Team Mojza, covering the content for AS Level 2022-24 syllabus. The content of these notes has been prepared with utmost care. We apologise for any issues overlooked; factual, grammatical or otherwise. We hope that you benefit from these and find them useful towards achieving your goals for your Cambridge examinations.

If you find any issues within these notes or have any feedback, please contact us at support@mojza.org.

Acknowledgements

Authors:

Proofreaders:

Designers:

© 2023 Mojza. All rights reserved.

The content of these notes may not be republished or redistributed without permission from Mojza. All diagrams have been designed by Team Mojza except where cited.



MOJZA





MOJZA

9702

AS Levels

PHYSICS

PRACTICAL PAPER 3 GUIDE

These notes are made to encompass the complete syllabus for 9702 from 2025 to 2027, with great attention and care for every topic. All information is curated in a simple, clear, and concise manner. The aim is to aid students and make learning easier in preparation for their exams. Team Mojza makes every effort to error-check all the content; if you find any discrepancies, please reach out to us at support@mojza.org.